

SHARP®

solar electricity

187 WATT

OnEnergy™
SYSTEM MODULE

NEC 2008 Compliant

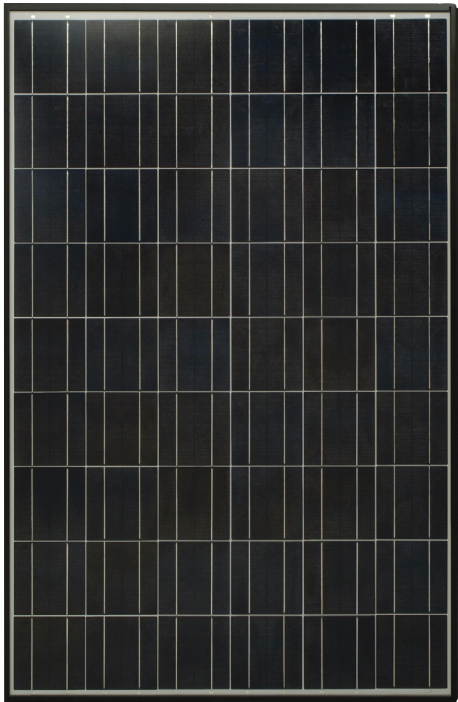

ND-187UC1

RESIDENTIAL 187 WATT
MODULE FROM THE WORLD'S
TRUSTED SOURCE FOR SOLAR.

This high-quality residential solar module is designed and engineered for use with the Sharp OnEnergy solar system. Sharp's OnEnergy system replaces the bulky look of traditional solar roof mounts with a clean, elegant appearance that blends beautifully with rooflines. Using breakthrough technology, made possible by nearly 50 years of proprietary research and development, this module incorporates an advanced surface texturing process to increase light absorption and improve efficiency.

ENGINEERING EXCELLENCE

Designed and engineered for use with Sharp's OnEnergy solar racking system, this module is the perfect combination of technology and design.

ADVANCED AESTHETICS

Black frame module, and associated racking with hidden hardware and tapered covers, delivers a clean, elegant appearance that blends beautifully with your home's roofline.

DURABLE

Tempered glass, EVA lamination and weatherproof backskin provide long-life and enhanced cell performance.

RELIABLE

25-year limited warranty on power output.

HIGH PERFORMANCE

This module uses an advanced surface texturing process to increase light absorption and improve efficiency.

[Designed for]

ONENERGY™
solar system by Sharp



Black frame and low profile racking complement roofline.



Laminated glass construction in a high torsion frame.

SHARP: THE NAME TO TRUST

When you choose Sharp, you get more than well-engineered products. You also get Sharp's proven reliability, outstanding customer service and the assurance of our 25-year limited warranty on power output. A global leader in solar electricity, Sharp powers more homes and businesses than any other solar manufacturer worldwide.

BECOME POWERFUL

187 WATT

ND-187UC1

NEC 2008 Compliant

Module output cables now 12 AWG with locking connectors

ELECTRICAL CHARACTERISTICS

Maximum Power (Pmax)*	187 W
Tolerance of Pmax	+10%/-5%
Type of Cell	Polycrystalline silicon
Cell Configuration	54 in series
Open Circuit Voltage (Voc)	32.7 V
Maximum Power Voltage (Vpm)	25.8 V
Short Circuit Current (Isc)	7.99 A
Maximum Power Current (Ipm)	7.25 A
Module Efficiency (%)	12.6%
Maximum System (DC) Voltage	600 V
Series Fuse Rating	15 A
NOCT	47.5°C
Temperature Coefficient (Pmax)	-0.485%/°C
Temperature Coefficient (Voc)	-0.36%/°C
Temperature Coefficient (Isc)	0.053%/°C

*Measured at (STC) Standard Test Conditions: 25°C, 1 kW/m² insolation, AM 1.5

MECHANICAL CHARACTERISTICS

Dimensions (A x B x C below)	39.1" x 58.7" x 2.3"/994 x 1491 x 57.5 mm
Cable Length (I)	43.3"/1100 mm
Output Interconnect Cable**	12 AWG with MC4 Locking Connector
Weight	39.6 lbs / 18.0 kg
Max Load	50 psf (2400 Pascals)

**A safety lock clip (Multi Contact part number PV-SSH4) may be required in readily accessible locations per NEC 2008 690.33 (C)

QUALIFICATIONS

UL Listed	UL 1703	
Fire Rating	Class C	

WARRANTY

25-year limited warranty on power output
Contact Sharp for complete warranty information

IV CURVES

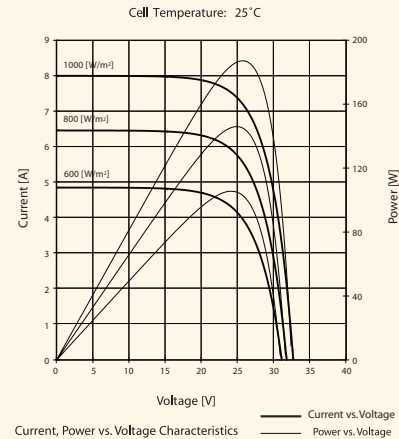

DIMENSIONS

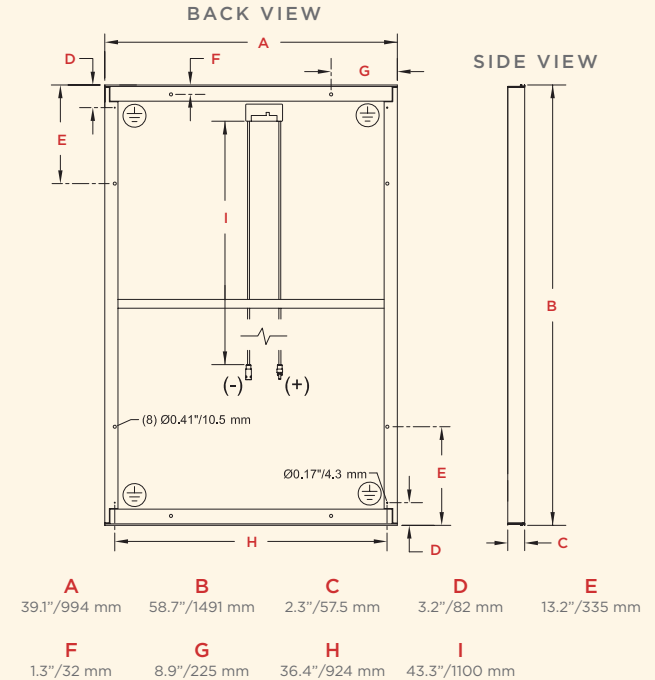

Contact Sharp for tolerance specifications

Design and specifications are subject to change without notice. Sharp is a registered trademark of Sharp Corporation. All other trademarks are property of their respective owners. OnEnergy and all related trademarks are trademarks or registered trademarks of Sharp Corporation and/or its affiliated companies. Contact Sharp to obtain the latest product manuals before using any Sharp device. Cover photo: Solar installation by Premier Power Renewable Energy, EL Dorado Hills, CA.

SHARP®

SHARP ELECTRONICS CORPORATION
5901 Bolsa Avenue, Huntington Beach, CA 92647
1-800-SOLAR-06 • Email: sharpsolar@sharpusa.com
www.sharpusa.com/solar